

ATKnee, All-Terrain Knee Walker
ATKnee, déambulateur tout-terrain avec
repose-genou
ATKnee, andador de rodilla todoterreno



**Step-by-Step
Assembly Guide**
Guide d'assemblage
étape par étape
Guía de montaje
paso a paso



Weight Capacity
Capacité de poids de
Capacidad de peso de
350 lbs (158 kg)

CAUTION: This Product Contains Natural Rubber Latex
Which May Cause Allergic Reactions.

ATTENTION : Ce produit contient du latex de caoutchouc
naturel, susceptible de causer des réactions allergiques.

PRECAUCIÓN: Este producto contiene látex de caucho
natural que puede producir reacciones alérgicas.

REF ATKNEE

What's Included:





P



Q

- A** Hand Brakes
- B** Hand Grips
- C** Brake Cable
- D** Handle Height Adjust Knob
- E** Basket
- F** Steering Column
- G** Locking Tiller Assembly Pin
- H** Swivel Lock Screw
- I** Kneepad
- J** Rear Wheels
- K** Front Wheels
- L** Seat Cam Lock
- M** Seat Height Adjust Pin
- N** Allen Key
- O** Memory Foam Seat Cover
- P** Step-By-Step Assembly Guide
- Q** Safety Guidelines

ATTENTION: This item does not come with a tire pump. A tire pump is needed to inflate tires. Check tire pressure routinely to ensure tires are inflated. **Do not inflate over 28 PSI.**

This guide applies to the following kneewalker:

Item Number	Description	Frame Color	Weight Capacity
ATKNEE	All-Terrain Knee Walker	Black	350 lbs (158 kg)

First: Open and Secure Handle Bar



1 Remove contents from carton and lay parts next to frame.



2 Turn front wheels to face forward so that tiller is on front of knee walker

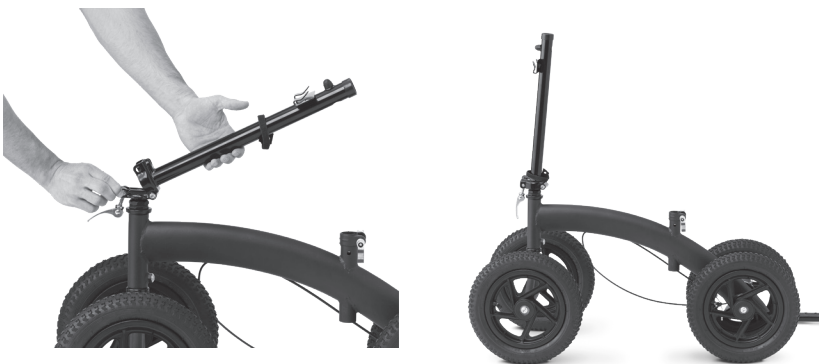

3 Raise tiller to the upright position. Push locking tiller assembly pin in until you hear a click. Make sure steering column is secure.



- 4** Rotate clockwise to tighten. Lift pin to upright position and push down tiller to secure.



- 5** Insert swivel lock screw into hole. Tighten using Allen key.



- 6** Insert handlebar into steering column with hand brake on front of knee walker.



- 7** Adjust to desired height and insert Handle Height Adjust Knob. Turn clockwise until tightened.

Next: Set Desired Kneepad Height



- 8** Lower the Kneepad to desired height.



- 9** Insert the Seat Height Adjust Pin into the hole. Lock pin in place by sliding the loop over the protruding end of the pin.



- 10** Rotate the seat cam lock clockwise to tighten the lock pad into place. Fold close to frame.

Now: Using the Hand Brakes



- 11** Adjust brake cable to reduce loose slack and prevent from catching on objects.

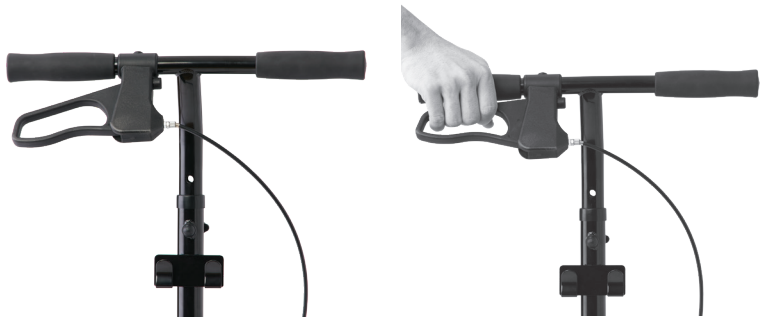

- 12** To apply the brakes, simply pull the hand brake lever with your fingertips toward the hand grip.



- 13** To lock the brakes, push brake handle down until you hear a click.

Attaching Accessories



- 14** Attach basket to designated hook on steering column.



- 15** Slip memory foam seat cover over kneepad. Ensure string is on back of kneepad. Tighten string and tuck excess string under kneepad.

Adjusting The Knee Pad Height



- 16** Uninstall the locking seat height adjustment pin. Adjust kneepad to desired height.



- 17** Reinstall the locking seat height adjust pin and secure it in place. Next tighten the Seat Cam Lock to lock pad in place.

Finally: Adjust Handle Height



- 18** To adjust the handle height, loosen the handle height adjustment knob below the handle by turning it counterclockwise until it can be removed. Adjust the handlebar to the desired height and reinstall the handle height adjust pin by turning it clockwise until it is tightened.

To Fold the Kneewalker



- 19** Release the Seat Cam Lock and seat height adjust pin.



20 Lower the knee pad all the way.



21 Loosen Tiller Cam Lock.



22 To fold down the handlebars, slide assembly to the side until the tiller is disengaged.



- 23** Fold the handle bars down until it rests on the knee pad. To reduce wear on the kneepad, remove the handlebar height adjust knob and store in a safe place.

Contenu



ATKnee, All-Terrain Knee Walker
 ATKnee, déambulateur tout-terrain avec
 repose-genou
 ATKnee, andador de rodilla todoterrano



P

ATKnee, All-Terrain Knee Walker
 ATKnee, déambulateur tout-terrain avec
 repose-genou
 ATKnee, andador de rodilla todoterrano



Q

A Freins à main

B Poignées

C Câble des freins

D Bouton de réglage de la hauteur des poignées

E Panier

F Colonne de direction

G Goupille de verrouillage du timon

H Vis du verrou pivotant

I Repose-genou

J Roues arrière

K Roues avant

L Verrou à came du repose-genou

M Goupille de réglage de la hauteur du repose-genou

N Clé Allen

O Housse du repose-genou en mousse à mémoire de forme

P Guide d'assemblage étape par étape

Q Consignes de sécurité

ATTENTION : Cet article n'est pas livré avec une pompe de pneu. Une pompe est nécessaire pour gonfler les pneus. Vérifier régulièrement la pression des pneus pour s'assurer qu'ils sont bien gonflés. **Ne pas dépasser la pression de gonflage maximale de 28 lb/po2.**

Ce guide s'applique au déambulateur avec repose-genou suivant :

Numéro d'article	DESCRIPTION	Couleur du cadre	Capacité de poids
ATKNEE	Déambulateur tout-terrain avec repose-genou	Noir	158 kg (350 lb)

Première étape : Déplier et fixer en place le guidon



- 1** Vider le contenu du carton et placer les pièces près du cadre.



- 2** Tourner les roues avant vers l'avant de façon à ce que le timon soit sur l'avant du déambulateur.



- 3** Relever le timon en position verticale. Enfoncer la goupille de verrouillage du timon jusqu'à ce qu'un clic se produise. S'assurer que la colonne de direction soit bien fixée.



- 4** Tourner dans le sens horaire pour serrer. Soulever le levier de la goupille en position verticale et appuyer sur le timon pour le fixer en place.



- 5** Insérer la vis du verrou pivotant dans le trou. Serrer à l'aide de la clé Allen.



- 6** Insérer le guidon dans la colonne de direction de façon à ce que les freins à main soient à l'avant du déambulateur.



- 7** Régler à la hauteur désirée et insérer le bouton de réglage de la hauteur des poignées. Tourner le bouton dans le sens horaire jusqu'à ce qu'il soit serré.

Prochaine étape : Régler le repose-genou à la hauteur désirée



- 8** Abaisser le repose-genou à la hauteur désirée.



- 9** Insérer la goupille de réglage de la hauteur du repose-genou dans le trou. Verrouiller la goupille en plaçant la boucle sur l'extrémité saillante de la goupille.



- 10** Tourner le verrou à came du repose-genou dans le sens horaire pour bien fixer le repose-genou. Le rabattre contre le cadre.

Utiliser les freins à main



- 11** Réduire le mou du câble des freins pour l'empêcher de s'accrocher à des objets.



- 12** Pour actionner les freins, simplement serrer la poignée des freins à main du bout des doigts en direction des poignées.

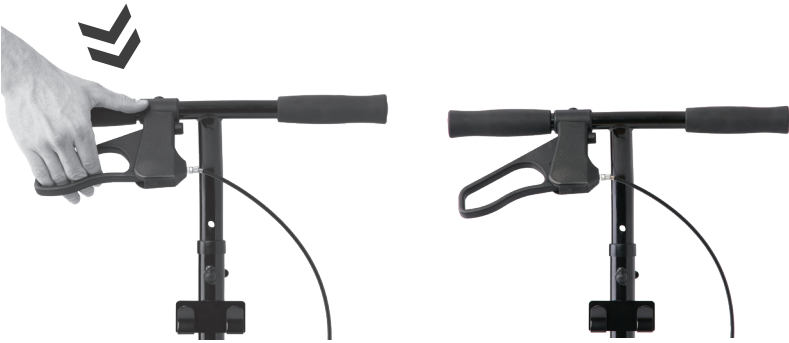

- 13** Pour bloquer les freins, appuyer sur la poignée des freins jusqu'à ce qu'un clic se produise.

Fixer les accessoires



- 14** Fixer le panier au crochet sur la colonne de direction.



- 15** Enfiler la housse en mousse à mémoire de forme sur le repose-genou. Vérifier que le cordon se trouve à l'arrière du repose-genou. Serrer le cordon et glisser la longueur superflue sous le repose-genou.

Régler la hauteur du repose-genou



- 16** Retirer la goupille de réglage de la hauteur du siège. Régler le repose-genou à la hauteur désirée.



- 17** Remettre la goupille de réglage de la hauteur du repose-genou et la fixer en place. Ensuite, serrer le verrou à came du repose-genou pour bien fixer le repose-genou.

Dernière étape : Régler la hauteur des poignées



- 18** Pour régler la hauteur des poignées, desserrer le bouton de réglage de la hauteur des poignées situé en dessous des poignées en le tournant dans le sens antihoraire pour le retirer. Régler le guidon à la hauteur désirée et réinstaller le bouton de réglage de la hauteur des poignées en le tournant dans le sens horaire jusqu'à ce qu'il soit bien serré.

Plier le déambulateur avec repose-genou



- 19** Relâcher le verrou à came du repose-genou et la goupille de réglage de la hauteur du repose-genou.



20 Abaisser complètement le repose-genou.

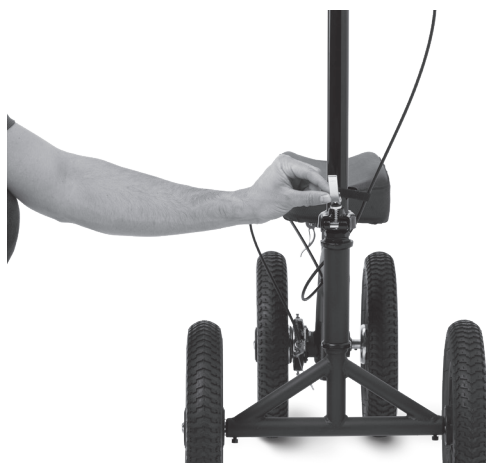

21 Desserrer le verrou à came du timon.



22 Pour rabattre le guidon, glisser le mécanisme de côté jusqu'à ce que le timon soit dégagé.



- 23** Plier le guidon jusqu'à ce qu'il repose sur le repose-genou. Pour réduire l'usure du repose-genou, retirer le bouton de réglage de la hauteur des poignées et le ranger en un endroit sûr.

Lo que se incluye:



ATKnee, All-Terrain Knee Walker
 ATKnee, all-terrain tout-terrain avec
 repose-genou
 ATKnee, andador de rodilla todoterreno



**Step-by-Step
 Assembly Guide**
**Guide d'assemblage
 étape par étape**
**Guía de montaje
 paso a paso**



Weight Capacity
 Capacité de poids de
 Capacité de peso
 350 lbs (158 kg)

Weight Capacity
 Capacité de poids de
 Capacité de peso
 350 lbs (158 kg)

Weight Capacity
 Capacité de poids de
 Capacité de peso
 350 lbs (158 kg)

ATKNEE

P

ATKnee, All-Terrain Knee Walker
 ATKnee, all-terrain tout-terrain avec
 repose-genou
 ATKnee, andador de rodilla todoterreno



**Safety
 Guidelines**
**Consignes
 de sécurité**
**Pautas de
 seguridad**



Weight Capacity
 Capacité de poids de
 Capacité de peso
 350 lbs (158 kg)

Weight Capacity
 Capacité de poids de
 Capacité de peso
 350 lbs (158 kg)

Weight Capacity
 Capacité de poids de
 Capacité de peso
 350 lbs (158 kg)

ATKNEE

Q

A Frenos de mano

B Empuñaduras

C Cable de freno

D Perilla de ajuste de
 altura del manillar

E Cesta

F Columna de
 dirección

G Pasador de montaje
 para bloquear el
 poste de dirección

H Perno de fijación
 basculante

I Reposarrodillas
 acolchado

J Ruedas traseras

K Ruedas delanteras

L Leva de fijación
 del asiento

M Pasador de ajuste
 de altura del asiento

N Llave Allen

O Cubreasientos
 de espuma con
 retención de forma

P Guía de montaje
 paso a paso

Q Pautas de seguridad

ATENCIÓN: Este producto no se suministra con una bomba de neumáticos. Se necesita una bomba de neumáticos para inflar las ruedas. Revise la presión de los neumáticos de forma rutinaria para asegurarse de que estén inflados. **No inflar por encima de 28 PSI.**

Esta guía rige para el siguiente andador de rodilla:

Número de artículo	Descripción	Color del armazón	Capacidad de peso
ATKNEE	Andador de rodilla todoterreno	Negro	350 lb (158 kg)



- 4** Gire en sentido horario para apretarla. Levante el pasador a la posición vertical y empuje el poste hacia abajo para asegurarlo.



- 5** Inserte el perno de fijación basculante en el orificio. Apriételo con la llave Allen.



- 6** Inserte el manillar en la columna de dirección con el freno de mano en la parte delantera del andador de rodilla.



- 7** Ajústelo a la altura deseada e inserte la perilla de ajuste de altura del manillar. Gire en sentido horario para apretarla.

A continuación: Configuración de la altura deseada del reposarrodillas



- 8** Baje el reposarrodillas hasta la altura deseada.



- 9** Inserte el pasador de ajuste de altura del asiento en el orificio. Bloquee el pasador en su lugar deslizando el bucle sobre el extremo sobresaliente del pasador.



- 10** Gire la leva de fijación del asiento en sentido horario para apretar la almohadilla de bloqueo en su sitio. Dóblela para que quede cerca del armazón.

Ahora: Uso de los frenos de mano



- 11** Ajuste el cable de freno para reducir la holgura y evitar que pueda engancharse con objetos.



- 12** Para accionar los frenos, simplemente tire de la palanca del freno de mano con los dedos hacia la empuñadura.



- 13** Para bloquear los frenos, empuje el freno de mano hacia abajo hasta escuchar un "clic".

Instalación de accesorios



- 14** Instale la cesta en el gancho previsto en la columna de dirección.



- 15** Deslice el cubreasientos de espuma con retención de forma sobre el reposarrodillas. Cerciñese de que el cordel está en la parte trasera del reposarrodillas. Apriete el cordel y acomode la longitud sobrante por debajo del reposarrodillas.

Ajuste de altura del reposarrodillas



- 16** Desinstale el pasador de bloqueo que permite ajustar la altura del asiento. Ajuste el reposarrodillas a la altura deseada.



- 17** Vuelva a instalar el pasador de bloqueo de ajuste de altura del reposarrodillas y fíjelo en su sitio. Luego apriete la leva de fijación del asiento para bloquear la almohadilla en su lugar.

Finalmente: Ajuste de altura del manillar



- 18** Para ajustar la altura del manillar, afloje el perno de ajuste de altura que se encuentra debajo del manillar girándolo en sentido antihorario hasta que pueda retirarlo. Ajuste el manillar a la altura deseada y vuelva a instalar el perno de ajuste de altura girándolo en sentido horario hasta que quede apretado.

Para plegar el andador de rodilla



- 19** Suelte la leva de fijación y el pasador de ajuste de altura del asiento.



20 Baje completamente el reposarrodillas.

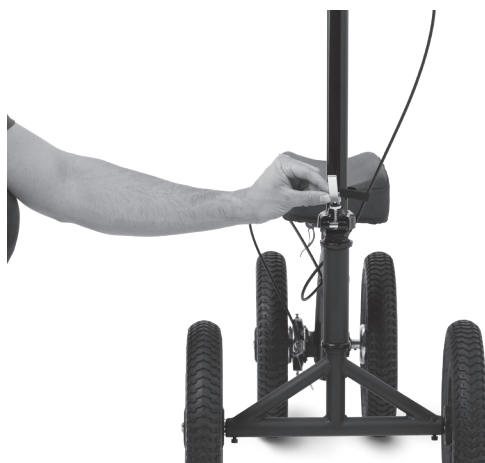

21 Afloje la leva de fijación del poste.



22 Para plegar el manillar, deslice el conjunto hacia un lado hasta que el poste se desenganche.



- 23** Pliegue el manillar hacia abajo hasta que descansa sobre el reposarrodillas. Para reducir el desgaste en el reposarrodillas, retire la perilla de ajuste de la altura del manillar y guárdela en un lugar seguro.



Medline Industries, LP, Three Lakes Drive, Northfield, IL 60093 USA
Medline United States
1-800-MEDLINE (633-5463)
medline.com | info@medline.com

Medline Canada

1-800-268-2848 | medline.ca | canada@medline.com

Medline México

01-800-831-0898 | medlinemexico.com | mexico@medline.com

Follow us | Suivez-nous | Siganos



Some products may not be available for sale in Mexico or Canada. We reserve the right to correct any errors that may occur within this brochure. © 2022 Medline Industries, LP. All rights reserved. Medline is a registered trademark of Medline Industries, LP.

Certains produits peuvent ne pas être en vente au Mexique ou au Canada. Nous nous réservons le droit de corriger toute erreur qui se glisserait dans cette brochure. © 2022 Medline Industries, LP. Tous droits réservés. Medline est une marque déposée de Medline Industries, LP.

Es posible que algunos productos no se comercialicen en México o Canadá. La empresa se reserva el derecho de corregir cualquier error en la información publicada en este folleto. © 2022 Medline Industries, LP. Todos los derechos reservados. Medline es una marca comercial registrada de Medline Industries, LP.

ATKNEE | PIC-00918 (Rev: V2 031822)